



WE.MOVE.FUTURE.

## Efficient lightweight design for vehicles of the future

[www.kirchhoff-automotive.com](http://www.kirchhoff-automotive.com)

 **KIRCHHOFF**  
AUTOMOTIVE

# Global player and development partner to the automotive industry

 KIRCHHOFF Automotive is a development partner to the automotive industry. We are active all over the globe as a full-service supplier for complex metal and hybrid structures in body-in-white, crash management systems, chassis applications and cross car beams.

Today, the family-owned company that was established in 1785 is part of the KIRCHHOFF Group, which includes the four divisions KIRCHHOFF Automotive, KIRCHHOFF Ecotec, WITTE Tools and KIRCHHOFF Mobility.

KIRCHHOFF Automotive is the largest business unit in the KIRCHHOFF Group, with more than 9,000 employees and about 30 production plants in 11 countries. As a global player, we offer complex body components through a cost effective logistical chain to our customers in Europe, Asia, and North America.

When developing innovative products and technologies, KIRCHHOFF Automotive focuses on cost-efficient lightweight design for vehicles of the future. During the development phase of new vehicle models, our customers can take advantage of our expertise in areas such as hybrid designs, combinations of steel and aluminum, or metal and plastic. By utilizing the advanced technology of partial press hardening, we are able to produce steel products with different strength ranges, therefore optimizing body components for weight and crash performance.

One of our core technologies is also the global Program Management which guarantees efficient project execution.

Our global production network includes the core technologies of forming, joining, and surface treatment, ensuring uniform manufacturing and production standards around the world. Products such as crash management systems, front end frames, and cross members are assembled into complete components at JIT plants that are located in the immediate vicinity of our customers.

Our focus is not only on the process and the machinery, but also most importantly on our employees. Only by staying highly motivated can we reach our goals together with our customers and be successful in the long term.

**J. WOLFGANG KIRCHHOFF**

*is the CEO of KIRCHHOFF Automotive. For four generations, the company has been owned by the Kirchhoff family. Corporate responsibility and social commitment are important factors in every corporate decision.*



# Our products

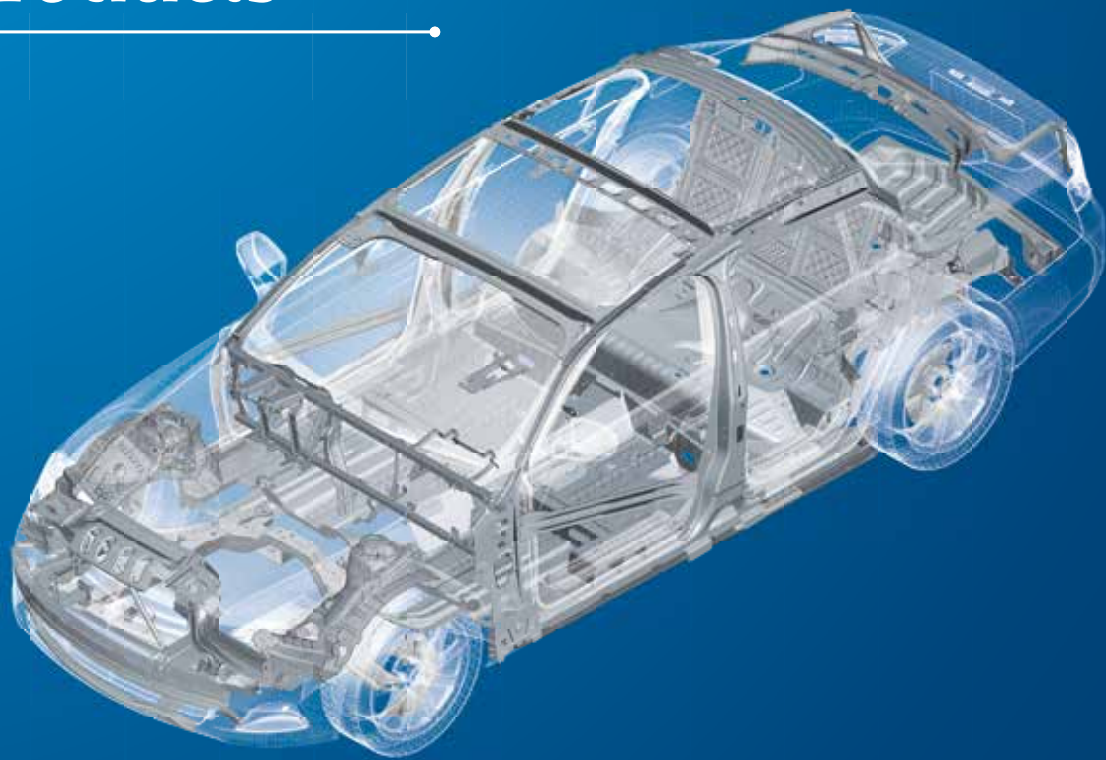

The whole is often greater than the sum of its parts. This is why we supply our customers with not only individual parts, but complex components as well. For the passenger car market, for example, we produce front-end frames, crash management systems, cross car beams, side and cross members, and mounting plates. For the commercial vehicle market, our product portfolio includes axle housings, cross members, front underrun protections, cab-in-white structures, and tank brackets.

Our products mainly consist of steel up to 12 mm of thickness and with strengths up to 2,000 MPa, as well as aluminum. Beyond that we combine different materials in hybrid construction for the automotive lightweight design. Nearly all international automobile manufacturers are our customers.



# Our core competencies

Everything from a single source: operating under this principle, we support our customers throughout the entire development and manufacturing process. This is our strength.



## Global Program Management

The platform strategies of big car producers require worldwide planning and production. Therefore, international presence and development competencies are important conditions in order to maintain competitiveness—today as well as in the future.

The Global Program Management of KIRCHHOFF Automotive provides an overview of the state of all KIRCHHOFF Automotive projects at any time, in

each stage. All procedures are standardized globally and comparable, and all necessary resources are allocated, accordingly.

Our globally networked manufacturing engineering centers ensure the implementation of coherent production systems at our sites in Europe, Asia and North America. As such, we can guarantee worldwide logistical concepts that are cost effective, and consistent high quality standards.

4



## Research & Development

- Design concept
- Finite elements calculation
- Prototyping
- Testing
- Technology development



## Tool construction

- Fixtures
- Transfer dies
- Progressive dies



### DETAILED INFORMATION

about our competencies and technologies can be found on our homepage

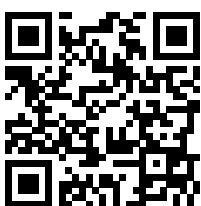

[www.kirchhoff-automotive.com](http://www.kirchhoff-automotive.com)

## Lightweight design

Basically very easy: Less material means less weight, which results in less fuel consumption, and ultimately less pollution.

The production of lightweight parts with higher strength needs the most modern technologies. Our holistic lightweight approach ensures a geometrically opti-

mal component design by using the right material in the right place.

This integral development process fulfills not only our customers' requests on products and processes, but also on cost optimization.

Front-end steel / plastic

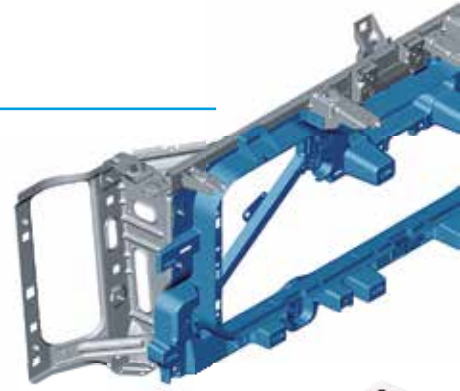

Aluminum support front axle in shell design



Hybrid crash management system



## Forming

- Cold forming
  - Pressing forces: 80-2,500 tons
  - Steel up to 1,200 Mpa
  - Thicknesses: 0.7-12 mm
- Hot forming
  - Pressing forces: 800-1,200 tons
  - Forming with subsequent hardening to high-strength steels up to 2,000 Mpa
- CNC bending
  - Open and closed section profiles in ultra high strength steel
  - Martensitic applications



## Joining

- Remote laser welding
  - 3D: Robot with scan box
  - 3D: Twin robot with flip flop
  - 2D: Laser position is moved by x-y table for high precision parts
  - 1D: Fixed laser position for linear tube applications
- MAG/ MIG welding
- Resistance welding
- Twin wire welding
- MIG brazing
- Gluing
- Mechanical joining
- Screwing
- Clinching
- Hybrid combinations



## Surface

- E-coating
- Powder coating
- Sealing
- Waxing



# Focus on employees

Our values “Honesty & Reliability”, “Trust & Respect”, and “Social, Environmental & Cultural Responsibility” provide a sense of direction and certainty. They set the foundation of our day-to-day business and apply to our behavior towards our colleagues, employees, supervisors and our business partners. Together, we work towards one goal: WE.MOVE.FUTURE.

## Family-owned company

For four generations, the KIRCHHOFF Group has been owned by the entrepreneurial Kirchhoff family. As an owner-managed, medium-sized company, we feel a connection to tradition and an obligation to the future.

Family-owned companies are the backbone of society. We are very aware of this responsibility. “Honesty & Reliability”, “Trust & Respect”, and “Social, Environmental & Cultural Responsibility” are the values which are at the core of our corporate culture.

Flat hierarchies and rapid decision-making paths drive our activities every day. Our company philosophy is based on sustainability.

## WORK LIFE FAMILY BALANCE

*This motto defines our efforts to become even more employee-friendly. Supporting family life is important to us. In particular, KIRCHHOFF Automotive encourages employees to balance private and professional matters by means of a family-friendly HR policy.*

## Our vision

- KIRCHHOFF Automotive is a global leader in designing and supplying best-in-class-structures for body and chassis of vehicles.
- The corporation creates sustainable and profitable growth while committing to be financially independent and family owned.
- KIRCHHOFF Automotive is performance oriented and stands for the highest level of customer service.
- The company develops its employees and actively supports their health and satisfaction.

## Generations and cultures

With over 9,000 employees on three continents—in Asia, Europe, and America—KIRCHHOFF Automotive links generations and cultures around the globe. Local managers have been intentionally selected for the top job at each of our production plants. They are the perfect link between acting locally and thinking globally.

Not only does our management meet regularly, but other hierarchy levels also meet for continuous exchange of experience.

## Our employees are important to us

Our annual employee development dialogue between manager and employee ensures continuous feedback concerning strengths and development potential. An individual development plan is agreed, including development activities that fit each employee’s personal needs. We also offer development opportunities and special programs such as a global leadership and a talent management program. We want to create a learning organization together with our employees to ensure that we are ready to meet future challenges, because WE.MOVE.FUTURE.

## Focus on people

In the KIRCHHOFF Automotive Production System (KAPS), the focus is not only on the process and machines, but also on people, who ensure that everything runs smoothly. The seven principles of KAPS apply to everyone, from corporate management, to administration, to production.







KIRCHHOFF Automotive Deutschland GmbH  
Am Eckenbach 10-14  
57439 Attendorn  
GERMANY  
Phone +49 27 22 6 96-0  
Fax +49 27 22 6 96-219  
info@kirchhoff-automotive.com

[www.kirchhoff-automotive.com](http://www.kirchhoff-automotive.com)

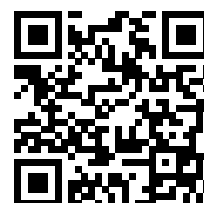

Image brochure E | 08.2017