

Supplier Shipping Guideline

KIRCHHOFF Europe-Asia

Preparation, packing and shipping of Dies, Sample Parts
and Checking Fixtures (Gauges)

Table of Contents

1	Target & General Rules.....	2
2	Dies & Checking Fixtures	3
2.1	Die preparation.....	3
2.2	Packaging	4
2.3	Labelling of Die packaging.....	6
3	Sample Parts – Packaging and Labelling	8
4	Measuring (CMM) reports.....	10

1 Target & General Rules

This guideline is valid for all KIRCHHOFF Automotive plants within Europe and Asia.

This guideline shall provide KIRCHHOFF suppliers rules and guidance for the correct shipment of Dies, Sample Parts and Checking Fixtures (Gauges).

Prior to the delivery of goods, supplier shall prepare the customs clearance documents (if customs clearance needs to be done).

For rules and guidance on how to prepare Customs Clearance documents, refer to the "Supplier Customs Guideline KIRCHHOFF Europe" in its latest version to be downloaded at KIRCHHOFF's homepage (Link: <https://www.kirchhoff-automotive.com/deEN/company/purchasing/downloads/europe>).

Supplier always has to provide the delivery tracking number to KIRCHHOFF's project responsible engineer (ME Engineer).

Supplier is responsible to inform all its logistic providers and their sub-suppliers, used for the delivery, to be aware of this guideline and the correct use of it.

Date	Version	Created by	Checked by	Released by
02.06.2022	04	D. Schneider	A. Stupperich	K. Lawory
01.03.2021	03	F. Innerhofer	A. Stupperich	K. Lawory
17.03.2017	02	D. Gierse	M. Pickhan	K. Lawory
02.12.2015	01	M. Pickhan	A. Stupperich	K. Lawory
12.02.2015	00	M. Pickhan	A. Stupperich	K. Lawory

2 Dies & Checking Fixtures

2.1 Die preparation

The following preparations for shipping have to be conducted by the supplier:

1. One sample part must be inside each Die operation. The part must have an anti-rust layer. In every unpainted zone an anti-rust layer must be applied as well.
2. If the Die will be shipped "opened" (upper and lower section of the Die separated):
A plastic foil must be used for covering the Die sections to avoid the infiltration of dust and dirt.
3. If the Die will be shipped "closed" (upper section lies on lower section of the Die):
Storage blocks between upper and lower section of the Die must be used as well as anchor plates.

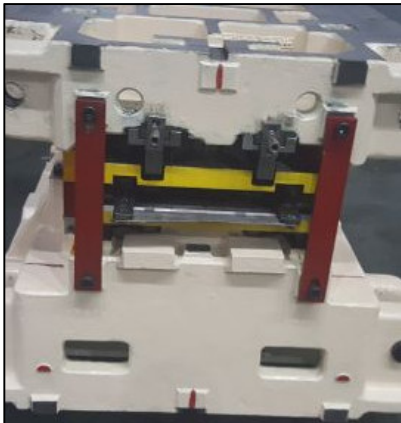

Date	Version	Created by	Checked by	Released by
02.06.2022	04	D. Schneider	A. Stupperich	K. Lawory
01.03.2021	03	F. Innerhofer	A. Stupperich	K. Lawory
17.03.2017	02	D. Gierse	M. Pickhan	K. Lawory
02.12.2015	01	M. Pickhan	A. Stupperich	K. Lawory
12.02.2015	00	M. Pickhan	A. Stupperich	K. Lawory

2.2 Packaging

a) Stamping Dies

- The Die has to be immobilized on the pallet by means of some crossbars, encasing it.
- The Die has to be packed in humidity bags.
- Wooden pallet has to be closed, forming a wooden box with the necessary reinforcements to handle it with chains.
- The top has to be bolted with screws (not with nails!) for opening the box for customs inspections.
- The pallet should be accessible from all four sides.

b) Welding and Assembly fixtures

- The packaging needs to ensure, that the welding and Assembly fixtures arrive at the factory without damage caused by transport or environmental influences.

Date	Version	Created by	Checked by	Released by
02.06.2022	04	D. Schneider	A. Stupperich	K. Lawory
01.03.2021	03	F. Innerhofer	A. Stupperich	K. Lawory
17.03.2017	02	D. Gierse	M. Pickhan	K. Lawory
02.12.2015	01	M. Pickhan	A. Stupperich	K. Lawory
12.02.2015	00	M. Pickhan	A. Stupperich	K. Lawory

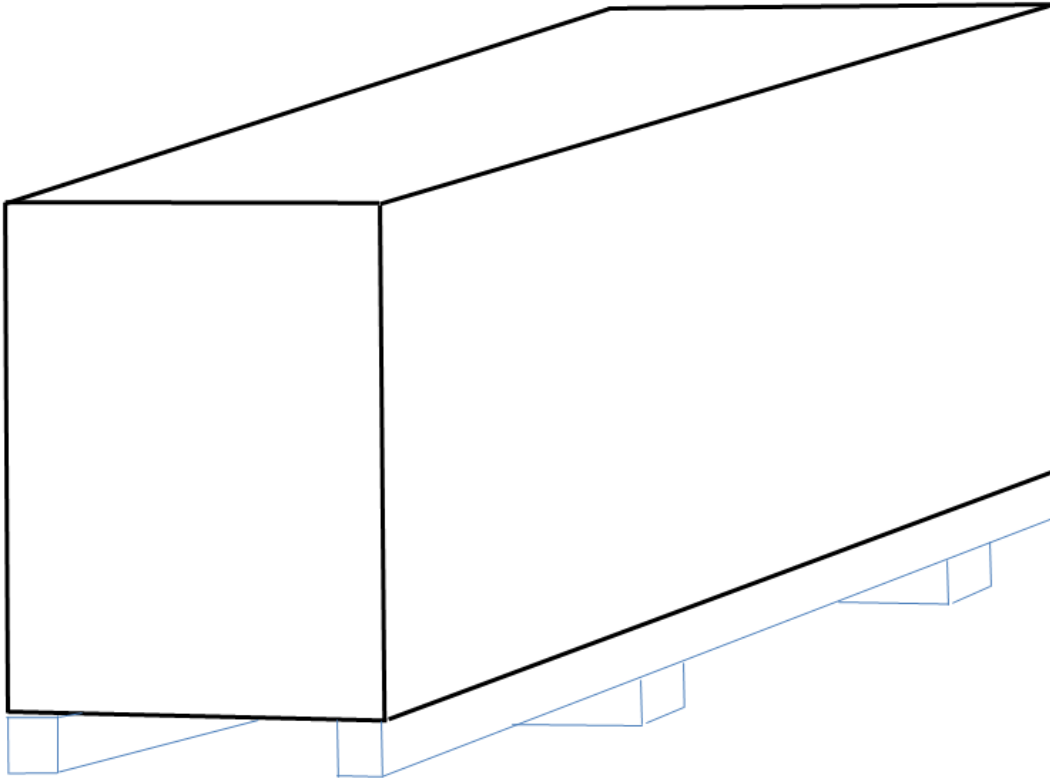

- It is mandatory that the wood is marked with IPPC logo, according to the international norms (ISPM):



- It is necessary to immobilize the boxes for transport preparation, as well as the proper content of them, to prevent moving during shipment.
- The Die must be fixed on the truck bed with wooden slats nailed on it and additionally fixed with transport belts or ropes.

Date	Version	Created by	Checked by	Released by
02.06.2022	04	D. Schneider	A. Stupperich	K. Lawory
01.03.2021	03	F. Innerhofer	A. Stupperich	K. Lawory
17.03.2017	02	D. Gierse	M. Pickhan	K. Lawory
02.12.2015	01	M. Pickhan	A. Stupperich	K. Lawory
12.02.2015	00	M. Pickhan	A. Stupperich	K. Lawory

In case of oversea transport

- OPEN TOP and a maritime container must be used.
- The container must be sealed by the shipping company.
- There should be a warning for the shipping company indicating that these boxes must fit into the hold of the ship.

The Die must be secured inside the container to avoid any type of damage.

2.3 Labelling of Die packaging

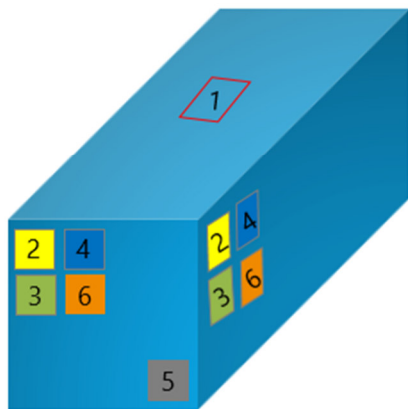

1 Top Side
Opening for customs inspection

2 On the 4 Lateral side
No stacking, vertical, rain protection

3 On the 4 Lateral side
Name an address of recipient

4 On the 4 Lateral side
Package number, dimensions, net weight, gross weight, indication of the number box and waybill number





5 On a lateral side inside a nailed plastic envelope
Contains packaging list or waybill and tool photos

6 On the 4 Lateral side
KA Shipping Label

Date	Version	Created by	Checked by	Released by
02.06.2022	04	D. Schneider	A. Stupperich	K. Lawory
01.03.2021	03	F. Innerhofer	A. Stupperich	K. Lawory
17.03.2017	02	D. Gierse	M. Pickhan	K. Lawory
02.12.2015	01	M. Pickhan	A. Stupperich	K. Lawory
12.02.2015	00	M. Pickhan	A. Stupperich	K. Lawory

Supplier is obliged to use official label called “KA tool shipping label” for **Label 6** (see picture on previous page).

The label can be downloaded on KIRCHHOFF homepage (<https://www.kirchhoff-automotive.com/deEN/company/purchasing/downloads/europe>) or can be provided by KIRCHHOFF project engineer on supplier’s explicit request. An instruction, how to use that label is part of the download document.

(1) Ship to KIRCHHOFF plant, or Integrator Mr. Musterman Musterstreet 1 12345 Mustercity, Worldwide		(2) KIRCHHOFF Project Number P*1234		Tool
(3) SAP Order nr.(N) 4500123456	(4) Supplier address / Sender Muster Toolshop GmbH Musterstreet 1, 12345 Mustercity			
		(5) Supplier Contact Person Max Mustermann		
(6) Pos. No in KA Purchase Order 10	(7) KIRCHHOFF KA Number 15780.40.601.01			
				
(8) Quantity (pieces) 1	(09) Tool Type Transfer Tool			
	(10) Production Date 20.04.2015	(11) Delivery note number 123456789		
				
(12) Phone number recipient: +49 2722696 0				
After reception of part, info to ME Engineer:		Mr. Mustermann		

!Attention!:

A copy of this label needs to be added to the standard shipping documents as well.

Date	Version	Created by	Checked by	Released by
02.06.2022	04	D. Schneider	A. Stupperich	K. Lawory
01.03.2021	03	F. Innerhofer	A. Stupperich	K. Lawory
17.03.2017	02	D. Gierse	M. Pickhan	K. Lawory
02.12.2015	01	M. Pickhan	A. Stupperich	K. Lawory
12.02.2015	00	M. Pickhan	A. Stupperich	K. Lawory







3 Sample Parts – Packaging and Labelling

Parts must be sorted correctly in the packaging. KIRCHHOFF does not accept any packages with mixed parts. If supplier intends to put different parts into one package, he has to make sure, that the parts are separated and cannot be mixed during the transport.

The chosen packaging should be sufficient to protect the parts against environmental influences and transport damages.

Prior to shipping of parts, KIRCHHOFF may request the Toolshop, to send photos of the parts, which are showing the appearance and packaging of those parts. These photos should enable the KIRCHHOFF staff to check the parts in terms of damages, as cracks, burrs, wrinkles, scratches, etc. and to check the packaging of the parts.

Supplier is obliged to use official label called "KA label incoming goods" only. The label can be downloaded on KIRCHHOFF homepage (<http://www.kirchhoff-automotive.com/de/unternehmen/einkauf/download/europa>) or can be provided by KIRCHHOFF project engineer on supplier's explicit request.

(1) Ship to KIRCHHOFF plant, or Integrator KIRCHHOFF Witte GmbH Hegestück 40 58640 Iserlohn, Germany		(2) KIRCHHOFF Project Number P*2103		PR
(3) SAP Order nr.(N)	4500737366	(4) Supplier address / Sender Muster Toolshop GmbH Musterstreet 1, 12345 Mustercity		
		(5) Supplier Contact Person Max Mustermann		
(6) Pos. No in KA Purchase Order 10	(7) Custom.ref.nr.(P) KIRCHHOFF KA Number 16757.40.002.01			
				
(8) Quantity (pieces) 15	(9) Part status (SLT / SST) SLT	(10) Customer Marking 3419	(11) Customer Quality Level 01K	(12) Parts for Carline / Product Unterfahrschutz kurz
	(13) Batch No. 		(14) Production Date 20.04.2015	
(15) Phone number recipient: +49 2722696 0			(16) Delivery note number supplier 1234567891	
After reception of part, info to ME Engineer: Mr. Mustermann				

Date	Version	Created by	Checked by	Released by
02.06.2022	04	D. Schneider	A. Stupperich	K. Lawory
01.03.2021	03	F. Innerhofer	A. Stupperich	K. Lawory
17.03.2017	02	D. Gierse	M. Pickhan	K. Lawory
02.12.2015	01	M. Pickhan	A. Stupperich	K. Lawory
12.02.2015	00	M. Pickhan	A. Stupperich	K. Lawory

Supplier has to place this label on packages / boxes highly visible.

Supplier shall not combine information of several parts on one label. This would prevent correct booking in KIRCHHOFF ERP system.

If supplier puts several parts into one box, he has to fill out one label per part and attach all labels to this box.

In addition to the label on the box, supplier has to print out one additional example of each label and attach it to its delivery papers.

If boxes are not properly packed or labelled, KIRCHHOFF reserves the right to charge additional costs resulting from this failure to suppliers account.

The instruction of how to fill out the label "KA label incoming goods" is included in the excel template of the label itself.

Date	Version	Created by	Checked by	Released by
02.06.2022	04	D. Schneider	A. Stupperich	K. Lawory
01.03.2021	03	F. Innerhofer	A. Stupperich	K. Lawory
17.03.2017	02	D. Gierse	M. Pickhan	K. Lawory
02.12.2015	01	M. Pickhan	A. Stupperich	K. Lawory
12.02.2015	00	M. Pickhan	A. Stupperich	K. Lawory

4 Measuring (CMM) reports

Measuring (CMM) documents needs to be linked as follows:

The following steps describe how to structure documentation correctly.

Page 1 - Picture of measured part

Page 2 - Touch direction

Page 3 - Orientation / alignment from datum

Page 4 - CMM report for surface, trim, holes etc.

Supplier Guideline "3D-measurement for individual parts and assemblies" in its latest version is available for download on KIRCHHOFF's homepage (Link: <https://www.kirchhoff-automotive.com/deEN/company/purchasing/downloads/europe>).

1. Picture of the measured part, showing how it is fixed on the gauge or free stage

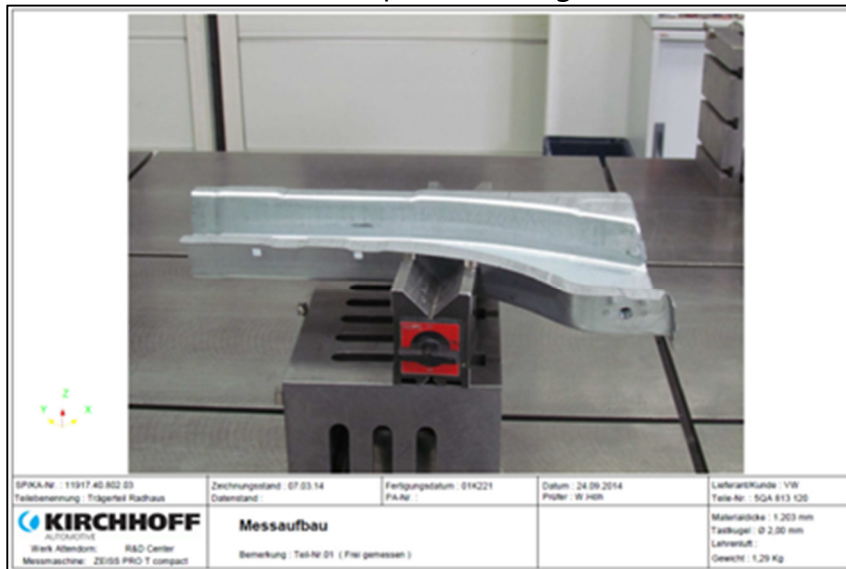

Date	Version	Created by	Checked by	Released by
02.06.2022	04	D. Schneider	A. Stupperich	K. Lawory
01.03.2021	03	F. Innerhofer	A. Stupperich	K. Lawory
17.03.2017	02	D. Gierse	M. Pickhan	K. Lawory
02.12.2015	01	M. Pickhan	A. Stupperich	K. Lawory
12.02.2015	00	M. Pickhan	A. Stupperich	K. Lawory

2. Touch direction

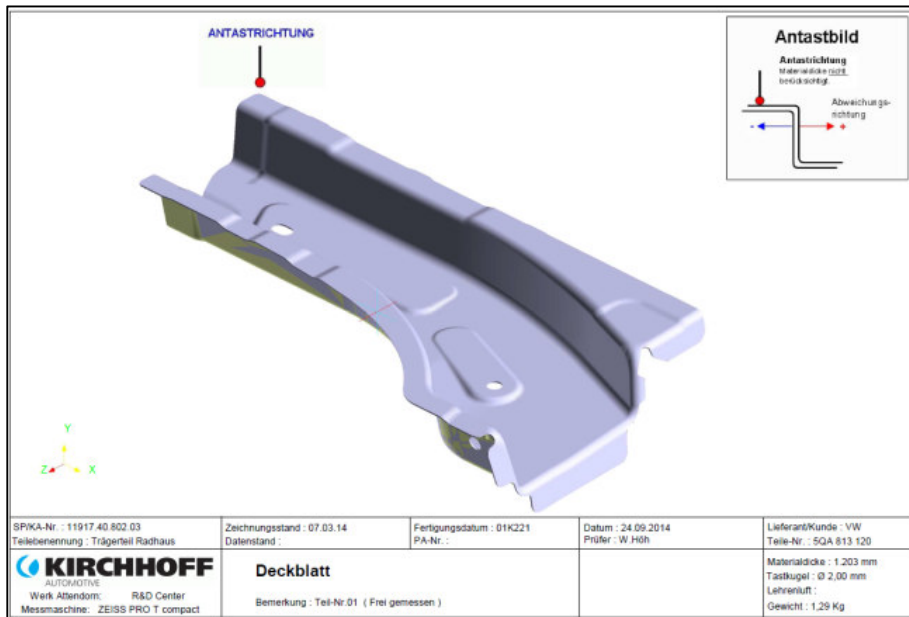

3. Orientation / alignment from datum

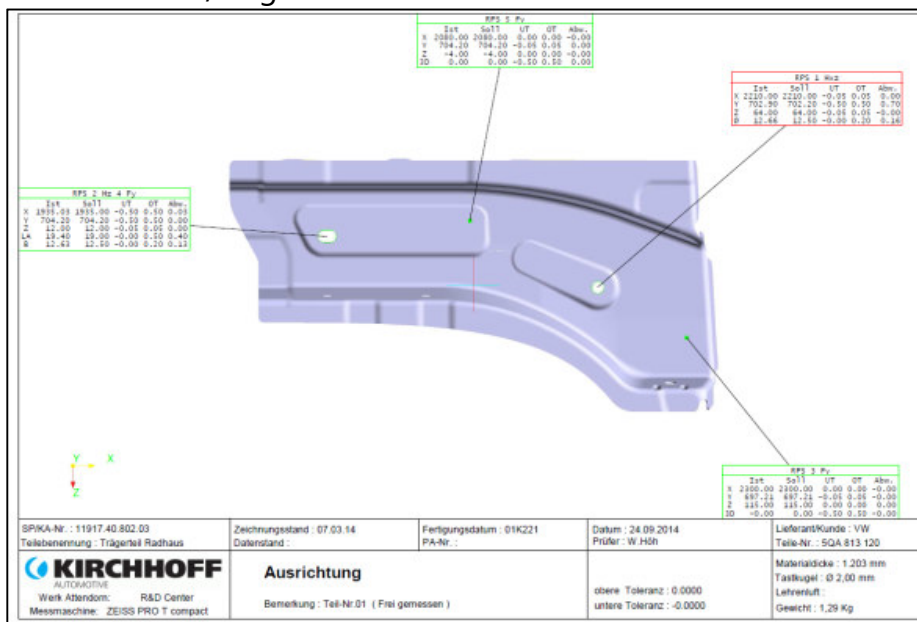

Date	Version	Created by	Checked by	Released by
02.06.2022	04	D. Schneider	A. Stupperich	K. Lawory
01.03.2021	03	F. Innerhofer	A. Stupperich	K. Lawory
17.03.2017	02	D. Gierse	M. Pickhan	K. Lawory
02.12.2015	01	M. Pickhan	A. Stupperich	K. Lawory
12.02.2015	00	M. Pickhan	A. Stupperich	K. Lawory

4. CMM report for surface, trim, holes etc.

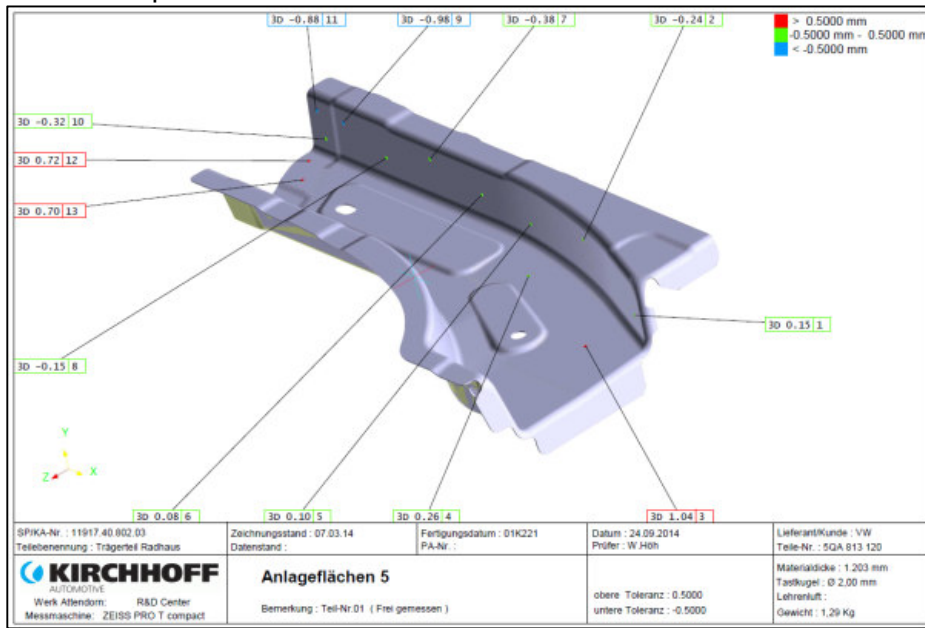

The CMM report has to be fixed on the measured part. The part has to be marked with T1-T3, so KIRCHHOFF is able to allocate it, and measure the part by itself.



Date	Version	Created by	Checked by	Released by
02.06.2022	04	D. Schneider	A. Stupperich	K. Lawory
01.03.2021	03	F. Innerhofer	A. Stupperich	K. Lawory
17.03.2017	02	D. Gierse	M. Pickhan	K. Lawory
02.12.2015	01	M. Pickhan	A. Stupperich	K. Lawory
12.02.2015	00	M. Pickhan	A. Stupperich	K. Lawory